

BUILDING A DECK OR PATIO

PLANNING & DEVELOPMENT
KEEPING YOU INFORMED.



SITE REGULATIONS

Development and construction in Whitecourt is regulated by the Land Use Bylaw.

- You require a Development and Building Permit if your proposed patio or deck is higher than 0.6 metres above design grade or greater than 15 square metres.
- All covered decks require permits.
- Patios and hard surfaced or covered decks are both included when calculating site coverage.

For more information on Development and Building Permits, read the information sheet entitled "Applying for Permits" which is available at the Town Office or online at www.whitecourt.ca.

SITE COVERAGE

Site coverage is calculated by adding all buildings, hard surfacing, and dividing that into total lot area. Maximum site coverage for most residential lots is 40%. The Development Officer can help you determine your property's site coverage.

FREQUENTLY ASKED QUESTIONS

What is the difference between a deck and a patio?

A deck is higher than 0.6 metres above design grade. A patio is less than 0.6 metres from design grade.

Is my wood deck calculated as part of my site coverage?

Only if it is hard surfaced or covered. Open decks that have planking with spaces between that drain to a permeable surface are not included in site coverage.

Do I need a permit to build a deck?

If the deck is higher than 0.6 metres from design grade to the floor of the deck, or if the deck's area is greater than 15 square metres, Development and Building permits are required.

Are there guardrail requirements when building a deck?

Contact an Accredited Safety Codes Officer to determine if guardrails are necessary.



UTILITY SAFETY PARTNERS

Click before you dig www.utilitysafety.ca.

Submit a locate request to ensure you don't come in contact with a dangerous underground utility.

BUILDING A DECK OR PATIO

PLANNING & DEVELOPMENT
KEEPING YOU INFORMED.

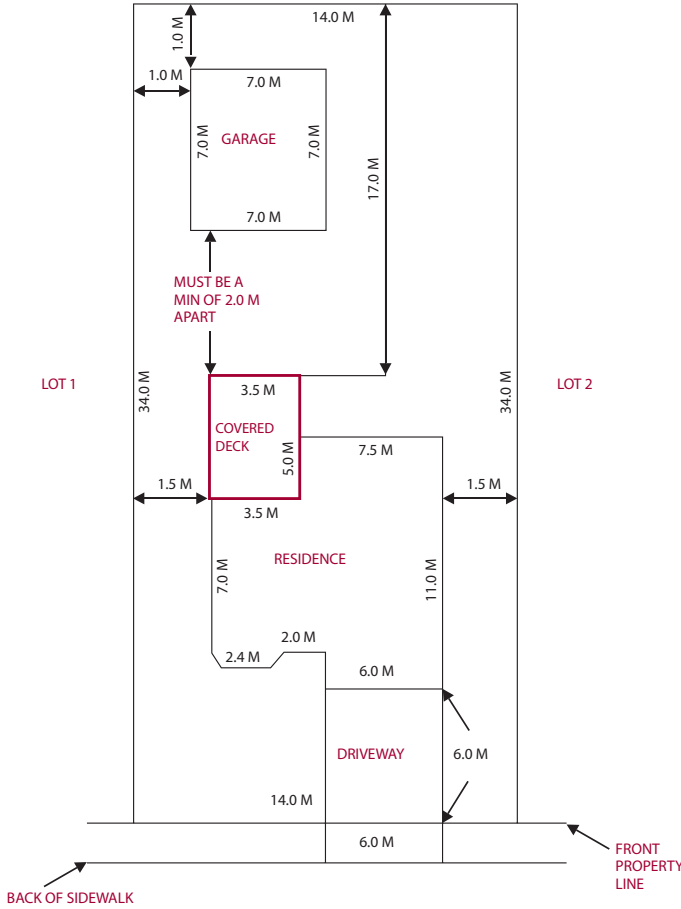

SAMPLE PLOT PLAN

A plot plan will be required to be submitted with your permit application (if required). See the sample to the left for what it should include.

FRONT YARD DECKS

Contact the Planning and Development Department to see if you can have an attached front deck.

REAR AND SIDE YARD DECKS

Attached decks must be a minimum of 1.5 metres from any side property line, and 7.6 metres from any rear property line. At least 2.0 metres must be left between an attached deck and any accessory structure.

Each lot is unique and a Development Officer would be happy to let you know what requirements apply to

UTILITY RIGHT OF WAY

A utility right of way is a registered easement on private land that allows the Town and utility companies the right to access the buried utilities or services that connect to your property. Permanent structures can not be built within a utility right of way.

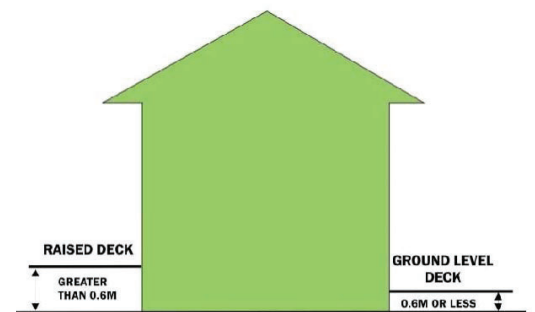

TOWN OF WHITECOURT - PLANNING & DEVELOPMENT DEPARTMENT

5004 52 Avenue, Box 509, Whitecourt Alberta T7S 1N6

Phone: 780.778.2273 Fax: 780.778.2062 Email: planning@whitecourt.ca

Monday to Friday 8:30 a.m. to 4:30 p.m. (Closed between 12:00 noon and 12:30 p.m.)